

Congratulations on your purchase of an Ecoflo® Biofilter system from Premier Tech Aqua (PTA). With the Ecoflo® Biofilter system, you have wisely chosen to protect your health as well as the environment. This manual contains information on the operation, operating guidelines, maintenance and warranties of the Ecoflo® Biofilter. For additional information, contact our customer service at 1 800 632-6356 or visit our website at PREMIERTECHAQUA.COM.

Operating Principle

Onsite wastewater treatment systems must respect applicable local rules and regulations. These systems are specifically designed to treat residential wastewater to such a level that treated effluent can be safely returned to the environment. Typically, an onsite wastewater treatment system is composed of 2 to 3 main treatment steps depending on site constraints: primary treatment, treatment system and if required tertiary treatment or polishing.

Primary treatment

The septic tank is the primary treatment. It clarifies wastewater by letting suspended solids settle to the bottom and retaining floating matter to prevent premature clogging of the treatment system. It is strongly recommended that the septic tank be equipped with an effluent filter. Every septic tank and effluent filter shall be installed according to the local regulations.

For more information on the operation, operating guidelines, maintenance and warranties of PTA's septic tanks with effluent filter, please refer to the septic tanks Owner's Manuals which can be found at premiertechaqua.com.

Treatment system

Once wastewater has passed through the septic tank, it then flows towards the Ecoflo® Biofilter. Inside the biofilter, a tipping bucket equally disperses the wastewater on specially designed plates which evenly distribute the wastewater on top of the filtering media. The wastewater then trickles through the natural fibrous filtering media. The treated effluent can then be discharged to the environment through an appropriate dispersal/disposal mean in accordance to local regulations.

The Ecoflo® Biofilter's operating principle allows the system to be used continuously or intermittently without requiring any special precaution or having any impact on the quality of the treatment. No specific action from the owner is required to start the system.

The model and the number of Ecoflo® Biofilters are determined by the number of bedrooms in a home or by the total domestic wastewater flow per day. The selection of the model also depends on the available surface area, the topography of the lot, as well as the type, permeability and depth of the natural soil on site.

Tertiary treatment/polishing

When required, the Ecoflo® Biofilter can be combined with PTA's disinfection filter (FDi), a UV disinfection unit (DiUV) or phosphorus removal unit (DpEC) to reduce pathogen concentrations or phosphorus.

For more information on the operation, operating guidelines, maintenance, and warranties of PTA's FDi, DiUV or DpEC, please refer to the products' Owner's Manuals, which can be found at premiertechaqua.com.

Ecoflo® Biofilter Models

There are many different models of Ecoflo® Biofilters and each model has different characteristics. The letters and numbers associated with the Ecoflo® Biofilter specify the model's characteristics, as presented in the following table with model **STB-570PR** as reference:

STB refers to the discharge method	ST = Open or perforated bottom (infiltration under the biofilter) STB = Watertight bottom (gravity or pumped discharge)
570 refers to the capacity ¹	500 = Nominal filtering media surface of 5.0 m ² (54 ft ²) 570 = Nominal filtering media surface of 5.7 m ² (61 ft ²) 650 = Nominal filtering media surface of 6.5 m ² (70 ft ²) 730 = Nominal filtering media surface of 7.3 m ² (79 ft ²) 750 = Nominal filtering media surface of 7.5 m ² (81 ft ²)
P refers to the shell	Not mentioned = Fibreglass B = Concrete P = Polyethylene
R refers to the pump	Not mentioned = No pump R = With pump

¹ Consult local regulations to know more about the daily design flow for each Ecoflo® model

You may also see **ECC-XXXX/P/DV CAN** or **ECC-XXX/P/DV USA**, where:

ECC refers to the shell	ECC = Ecoflo® Coco Concrete ECP = Ecoflo® Coco Polyethylene ECF = Ecoflo® Coco Fibreglass
XXXX refers to the daily flow	XXXX = Daily flow in liters (CAN) XXX = Daily flow in USgal (USA)
P refers to the discharge method	G = Gravity discharge P = Pumped discharge O = Open or perforated bottom (infiltration under the biofilter)
DV refers to dosing volume present in the bottom of unit	DV = Dosing volume

Installation Diagrams

NOTE: The installation diagrams below show Ecoflo® Biofilters with polyethylene shells.

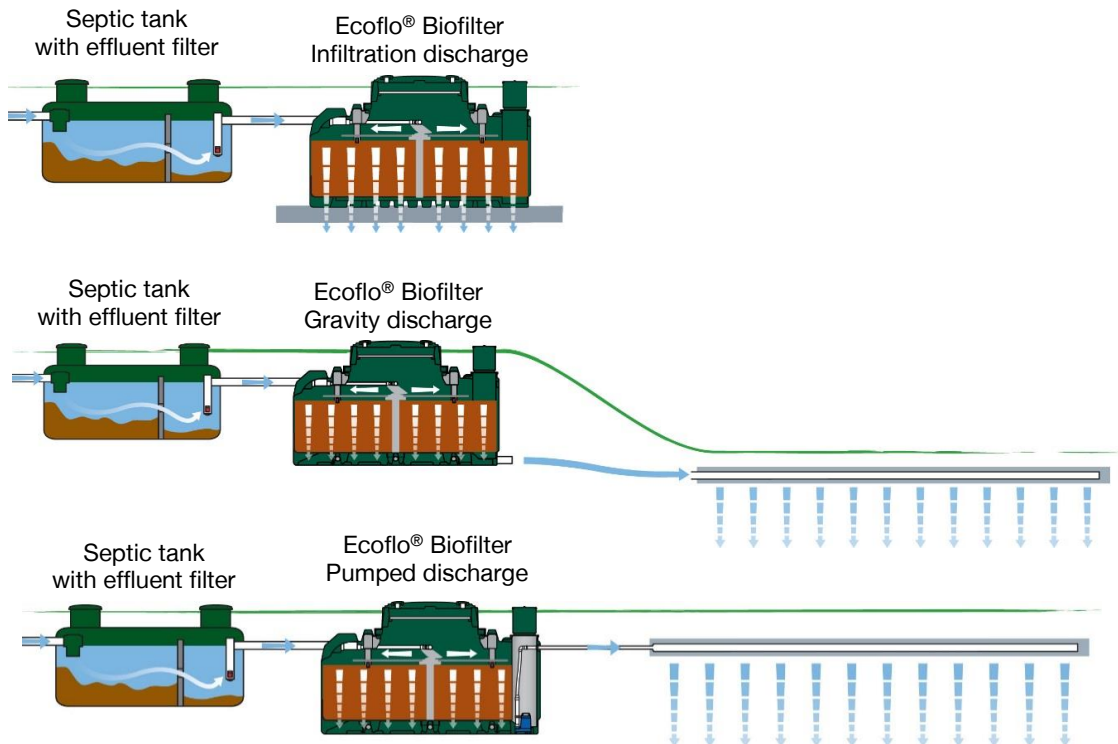

Operating Guidelines

Type of wastewater that can be treated by an Ecoflo® Biofilter:

Domestic wastewater (for example: wastewater from isolated dwellings).

It is NOT RECOMMENDED to discharge any of the following substances into the septic system:

- Oil and grease (motor oil, cooking oil, etc.);
- Wax and resins;
- Paints and solvents;
- Any kind of petroleum product;
- Any kind of pesticide;
- Any kind of septic tank additive;
- Any kind of toxic substance;
- Anything not easily biodegradable (for example, coffee beans, cigarette butts, sanitary napkins, tampons, condoms, cotton swab, etc.).



AND

- **NEVER** open or go inside the septic tank or the Ecoflo® Biofilter.
- **Keep all lids of the septic system accessible at all times. NEVER** cover them with mulch, dirt or any permanent structure (patio, swing, shed, etc.).
- **Make sure all lids of the septic system are at least 50 mm (2") above the surface of the landscaped lot.**
- **NEVER** install a riser on a fiberglass open bottom or polyethylene Ecoflo® Biofilter access.
- **NEVER** install more than **ONE (1) RISER** on a concrete or fiberglass watertight bottom Ecoflo® Biofilter access. Use only PTA products. For the fiberglass watertight bottom Ecoflo® Biofilter, also use the four (4) polystyrene foams provided by PTA.
- **NEVER** plant trees within 6 m (20') of the Ecoflo® Biofilter lid and within 2 m (6'6") of the absorption bed.
- **NEVER** connect a drain pipe, roof gutter, sump pump or air conditioner drain to the septic system.
- **NEVER** discharge content or water from a water softener backwash, a spa or pool in your septic system.
- **NEVER** discharge wastewater from a recreation vehicle (camping trailer, caravan, etc.) into any of the components of your septic system.
- **NEVER** use automatic toilet bowl cleaners.
- **DO NOT** let anything accumulate on top of the septic system (for example, blown snow, backfill, landscaping, rocks, etc.) less than 5 m (16' 5") of your septic system's lid.
- **Maintain a minimal distance of 6m (20')** between the bottom of a slope, an embankment or a retaining wall and the lids of your septic installation.

By respecting these guidelines, you contribute to the proper operation of your septic system and help prolong the life of your Ecoflo® Biofilter filtering media. Failure to abide by these guidelines may, at Premier Tech Aqua's discretion, render the warranty invalid.

Owner's responsibility

The owner must respect all existing laws and regulations regarding the system's effluent quality and its discharge into the environment. The owner of the wastewater treatment system is responsible for its installation, operation and maintenance.

The warranty of the system begins at the time of purchase. In the case where the start-up of the system is delayed, the customer must obtain a written confirmation from his or her the municipality or the authority responsible for the application of the regulation in effect. A copy of this confirmation must also be sent to Premier Tech Aqua in order for the annual maintenance of the system to be postponed. A request for a delayed system start-up will not be granted later that one (1) year after the date of purchase of the system.

NOTE: In regions where the Filter for Life warranty program offered by the manufacturer applies, Premier Tech Aqua will request that the annual fee be paid annually and without any interruption to ensure that all admissibility conditions to the program remain valid.

Keep heavy objects off your septic system

Never drive a vehicle or place objects weighing more than 225 kg (500 lb) within 5 m (16'5") of the lid of your Ecoflo® Biofilter. If you are planning any kind of landscaping or any other type of work on the property (i.e.: snow removal, lawn mowing, excavation, etc.), **make sure you advise all those involved**, so they do not damage your septic system. It is recommended to note where of your septic system elements are located.

About your home

Your home must be equipped with an air vent that is in proper working order and all plumbing must comply with the applicable standards of the building code in your location. Every septic tank must be ventilated by an air duct with a diameter of at least 100 mm (4") or be connected to the air vent of the isolated dwelling being served. Premier Tech Aqua strongly recommends using a pipe with a diameter of 100 mm (4") for the air vent.

Any change in the use of your home or any modification to your Ecoflo® Biofilter must be authorized by the local authorities, and Premier Tech Aqua must be advised. If this requirement is not fully met, the warranty for your Ecoflo® Biofilter will be null and void.

Maintenance

Septic tank

Empty your septic tank regularly. This helps to keep your septic system in proper working order. Every septic tank and effluent filter shall be inspected and maintained as prescribed by local regulations.

If your home is equipped with a garbage disposal or a sewage pump, we strongly recommend emptying your septic tank more frequently. Using this kind of equipment increases the amount of sludge in the septic tank.

To have a complete record of the maintenance done on your septic system, we recommend you keep the proof of maintenance (invoice) with this Owner's Manual.

IMPORTANT: Septic tanks can be emptied in several ways that can be classified into two categories: **complete emptying and selective emptying**. Complete emptying, the most common, consists of completely pumping the contents of the septic tank. It's easy to check if the work was properly done because the septic tank will be completely empty when the vacuum truck leaves the site. Selective emptying is divided into two sub-categories: with a filter (or recycled) or without a filter. The method with a filter requires a truck that has been adapted for this type of emptying, that is, one that separates and retains the solids in the wastewater. The mechanically clarified water is then returned to the septic tank. The selective method without a filter allows the solids to settle while in the truck before the water is returned to the septic tank. As such, in an effort to ensure the Ecoflo® Biofilter continues to perform optimally, **it is very important that you ensure that the water that is returned to the septic tank has been properly clarified and does not contain or contains very few suspended solids**. We also recommend you call one of the members of PTA's local partners from WALTER Wastewater Treatment Services. He will assist and verify if the work is done according to your specific needs to best protect your Ecoflo® system.

Effluent filter

Under normal operating conditions, as described in this manual, an effluent filter that complies with local regulations should operate efficiently for many years. It must be cleaned every time the septic tank is emptied, as established or recommended by local authorities.

Ecoflo® Biofilter

The owner of a biofiltration system **shall follow the manufacturer's recommendations regarding the maintenance of the system**. For that purpose, he must at all times have a valid contract with the manufacturer or its local representative and, depending on the local regulations, **a copy of the contract may have to be filed to the authorities**.

Annual maintenance is important to ensure optimal performance of your Ecoflo® Biofilter and essential to maintain its warranty. Therefore, your biofilter must be serviced annually and that its maintenance contract be renewed every year for the duration of its useful life.

The maintenance of your Ecoflo® Biofilter is done by our local WALTER Wastewater Treatment Services partner network. This service includes a visual inspection of all components and a verification of the operation as well as maintenance of the filtering media. **For maintenance purposes and to replace the filtering media, you must ensure that your system's lid is easily accessible.** Never cover or bury the lid of the Ecoflo® Biofilter. After each inspection, you will be given a maintenance record. Keep it with this manual in a safe place.

At the end of its eight (8) year life span, the filtering media is analyzed by one of our authorized agents. If the filtering media has not been abused and the operating guidelines have been respected, the filtering media might not have to be replaced and can be used for an additional year. **However, your Ecoflo® Biofilter's filtering media must be replaced before the system's treatment capacity and performance begins to deteriorate.** The filtering media is easily pumped out using a truck adapted to emptying septic tanks. The new filtering media is then installed by an authorized agent or the pumper.



To know more about the maintenance of your Ecoflo® Biofilter, refer to your Maintenance Agreement. If you need help or more information, please call our Customer Service Department at **1 800 632-6356** or visit our website at **PREMIERTECHAQUA.COM**.

Ecoflo® Biofilter with Pump

Some Ecoflo® Biofilters are equipped with a pumping station that directs the treated effluent to an appropriate disposal mean according to local regulations. The electro-mechanical components are included in this system. Here are some of the details.

Visual and audio alarm system

The pumping station is equipped with a high-water-level float connected to an alarm system. This alarm system must be installed inside the residence (home) so it can be heard when it is activated. The following information describes how this system works.

A red indicator lights up when the water level in the Ecoflo® Biofilter is unusually high. If an alarm is activated, contact Premier Tech Aqua's After-Sales Service Department because the incident has to be checked. To silence the alarm, press the **"SILENCE"** button.

The **"TEST"** button lets you check if the alarm system is working properly. During a test, the red indicator should light up and an audio alarm should be heard.

In the event of a power failure, the alarm system continues to function on an emergency 9-volt alkaline battery (not supplied). Using a rechargeable battery is not recommended.

NOTE: Replace the emergency battery every 12 months, each time the alarm is activated or whenever there is a power failure. If the battery is weak, the system will beep once every minute. When this occurs, replace the battery immediately.

To replace the 9-volt battery:

- Disconnect the alarm box and remove it from the wall (the battery must be inserted on the side of the box).
- Open the cover of the 9-volt battery compartment and replace the battery with a 9-volt alkaline battery.
- Close the cover, reinstall the box on the wall and reconnect it.
- If the alarm is activated, press the **"RESET/TEST"** button to initialize it.



Pumping station
Alarm box

Electrical connections

All electrical connections must be done by a **certified electrician** and using seal connectors is mandatory. Premier Tech Aqua recommends installing the power box on top of the pumping station's insulating board to avoid humidity problems.

Use two (2) separate circuit-breakers, one to operate the pump and the other to connect the alarm box. Do not connect anything else to these circuit-breakers (for example, a household appliance). They must be used exclusively for the pump and the alarm box.

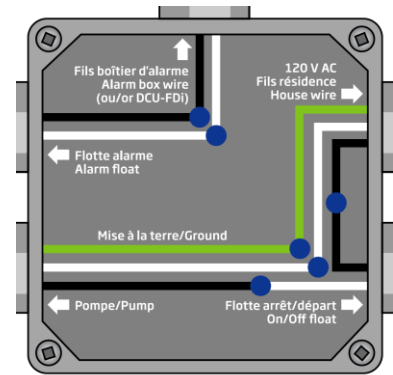

Electrical junction box

What to do in case of...

An activated alarm

If an alarm is activated, unrelated to a power failure, contact Premier Tech Aqua's After-Sales Service Department so the problem can be identified and corrected.

A prolonged power failure

If a power failure that occurs during winter is prolonged, protect the components of your septic system against freezing. If you have any questions to restart your system, contact Premier Tech Aqua's After-Sales Service Department.

Flooding

Certain sites are prone to flooding or to rises in groundwater levels. This can lead to a malfunction in your septic system or alter the performance of your Ecoflo® Biofilter. If this happens, contact Premier Tech Aqua's After-Sales Service Department.

Backflow

Backflow rarely occurs. But if it does happen, the septic tank is usually the cause. Your septic tank installer or septic tank pumper can generally take care of the situation.

Odours

All septic systems are apt to generate gases and odours. The position of the air vent, as well as other factors unrelated to the Ecoflo® Biofilter itself, can prevent septic gases from dispersing properly and lead to odours. If this happens, contact Premier Tech Aqua's After-Sales Service Department.

If you have any questions or comments, do not hesitate to contact Premier Tech Aqua at 1 800 632-6356.



☎ **1 800 632-6356**
📠 418 862-6642
✉ pta@premiertech.com
PREMIERTECHAQUA.COM

The information contained in this document is based upon the latest information available at the time of publication and is designed to provide you with a general introduction to our products. We make no warranties or representations as to its accuracy. We are continually updating and improving our products and reserve the right to amend, discontinue, alter or change specifications and prices without prior notice. Ecoflo® is a brand of Premier Tech Ltd. The Ecoflo® Biofilter is protected under patents: CA2499637; US7097768; ES2285173; EP1539325 (BE, FR). Notice issued on 2016-01-12. For current data regarding all patent application(s) and patent(s) for this product or any part thereof, consult the website patentmarking.premiertech.com (references: 3685).

© Premier Tech Ltd, 2016

Certificate of Warranty for Ecoflo® Biofilters

1. PREAMBLE

Premier Tech Technologies Ltd. (hereinafter called "Premier Tech") is proud to provide its customers with an exclusive wastewater treatment system guaranteed by an innovative Warranty.

For the application and interpretation of this Warranty, "Customer" shall mean the person who has purchased an Ecoflo® Biofilter (hereinafter called "Initial Purchaser"), for a residential installation, as well as any subsequent purchaser (hereinafter called "Subsequent Purchaser(s)"), in accordance with the provisions of section 8 of this Warranty. "Successor(s)" shall mean any other person entitled to exercise the same rights as the Customer under the law.

2. NATURE OF THE WARRANTY

2.1. Ecoflo® Biofilter

Premier Tech warrants to the Customer that the filtering media of the Ecoflo® Biofilter shall function properly for a period of eight (8) years from the date of purchase by the Initial Purchaser (proof of purchase required).

Except as provided in sections 2.2 and 2.3 below, Premier Tech also warrants all parts of the Ecoflo® Biofilter components against any manufacturing defect for a period of ten (10) years from the date of purchase by the Initial Purchaser (proof of purchase required). The first two years of the warranty also cover the labour.

2.2. Concrete

Premier Tech does not offer any additional Warranty on the shell of the concrete Ecoflo® Biofilter. Accordingly, the Customer shall rely on the local concrete manufacturer's Warranty policy.

2.3. Pump, floats, alarm box and junction box

The pump, floats, alarm box and junction box included with the Ecoflo® Biofilter are guaranteed for two (2) years (parts only), from the date of purchase by the Initial Purchaser (proof of purchase required). The first year of the warranty also covers the labour.

Premier Tech's conventional Warranty is expressly limited to the text of this Certificate and valid provided the Ecoflo® Biofilter was installed in accordance with applicable regulations and with the manufacturer's recommendations.

3. NOTICE

For this Warranty to be valid, the Customer must notify Premier Tech in writing immediately upon the appearance of any indication of an anomaly or irregularity in the Ecoflo® Biofilter.

Such notice shall be mailed to Premier Tech's Head Office at 1, avenue Premier, Rivière-du-Loup, Québec, G5R 6C1, CANADA or by facsimile at (418) 862-6642.

Upon receipt of this notice, Premier Tech shall examine the situation and, if necessary, take appropriate corrective measures in accordance with the terms of this Warranty.

4. GENERAL EXCLUSIONS

The following damages or problems are excluded from the Warranty:

(a) Any damage or problem caused by a fortuitous event or "force majeure," such as, without limiting the generality of

the foregoing, an earthquake, a flood, frost, hurricane, landslide, explosion or dynamiting;

(b) Any damage or problem caused by the fault or act of a third party including, without limiting the generality of the foregoing, the execution of landscaping work;

(c) Any damage or problem arising from a defective installation carried out by a person trained by Premier Tech, or any installation, modification, correction or addition carried out by a person not trained by Premier Tech;

(d) Any damage or problem arising from any installation, modification, correction or addition to the treatment system carried out after installation of the Ecoflo® Biofilter without prior written approval from Premier Tech;

(e) Any damage or problem caused by the use of a septic tank that does not comply with the applicable regulations and/or with Premier Tech's specifications, as described in the Owner's Manual;

(f) Any damage or problem, if it is shown that the usage of the Ecoflo® Biofilter was not in accordance with the instructions and guidelines described in the Owner's Manual;

(g) Any damage or problem, if the maintenance of the Ecoflo® Biofilter was not carried out by a person authorized by Premier Tech, in accordance with the Maintenance Agreement;

(h) Any damage or problem caused by an omission or act of the Customer or the Customer's Successors including, without limiting the generality of the foregoing, refusal to allow access to the system for maintenance;

(i) Any damage or problem, if it is found that the Customer or the Customer's Successors have modified or changed the use of the property serviced by the Ecoflo® Biofilter resulting in the alteration of the nature or quality of wastewater being treated and/or that constitutes a violation of the applicable regulations;

(j) Any damage or problem caused by and/or resulting from the work carried out to access to the Ecoflo® Biofilter, including, without limiting the generality of the foregoing, excavation, snow removal or demolition;

(k) Any damage or problem resulting from the condition of the site or of the soil and not reported or not properly reported to Premier Tech by the Customer or the person undertaking the site investigation.

5. PARTICULAR EXCLUSIONS

It is further expressly understood that the Customer may not carry out or cause to be carried out any repair or verification of the Ecoflo® Biofilter sold to him, or attempt to carry out any work or to apply any corrective measures whatsoever to said work, before notifying Premier Tech in accordance with the provisions of section 3 of this Warranty and before Premier Tech has visited the site, within a reasonable time following receipt of said notice, to assess the situation.

If the Customer carries out or causes to be carried out repairs, or attempts to repair or to apply corrective measures of any kind whatsoever to the Ecoflo® Biofilter sold to him without prior authorization by Premier Tech, this Warranty shall be considered null and void and Premier Tech shall be considered completely discharged from any and all of its obligations under this Warranty.

Certificate of Warranty for Ecoflo® Biofilters

6. INDEMNITIES AND DAMAGES

Subject to the application of the provisions and exclusions provided for in this Warranty, Premier Tech's liability and obligations regarding any corrective measure carried out or any attempt to correct an indicated problem shall be limited to replacing the filtering media and/or one or several components of the Ecoflo® Biofilter and to supplying the required labour, if applicable.

7. LIMITATION OF LIABILITY

Premier Tech's compensation or indemnification obligation shall be limited to the provisions of section 6 of this Certificate of Warranty and Premier Tech shall not be held liable for any other damage or loss that may have been suffered or incurred by the Customer or any third party in connection with the Ecoflo® Biofilter, its parts and/or components which originate thereof.

No additional warranty, express or implied, hence excluding any direct or indirect consequential damages (not limited to but including third parties loss) concerning the design, sale or use of the Ecoflo® Biofilter and/or services provided by Premier Tech is hereby granted. Premier Tech's liability under its warranty obligation shall in no case exceed the cost of the Ecoflo® Biofilter.

8. TRANSFER OF OWNERSHIP

In the event of transfer of ownership, sale, assignment or disposal in any way whatsoever of the Customer's property to a third party, this Warranty shall continue to apply if and only if the Subsequent Purchaser or the Successor confirms, by forwarding the attached "Notice of New Property Owner" to Premier Tech within a reasonable delay, that he/she is the new owner of the property, he/she understands and is aware of the content of this Certificate of Warranty and accepts its terms and conditions.

The person who proceeds with the transfer, sale, assignment or disposal of any way whatsoever of the property undertakes to hand over to the Subsequent Purchaser or the Successor the Certificate of Warranty provided upon completion of the work, as well as the Owner's Manual and, if applicable, the Maintenance and Environmental Monitoring Program for the Ecoflo® Biofilter. Failure to abide by the terms and conditions of section 8 of this Certificate of Warranty may, at Premier Tech's discretion, render it invalid or to be rejected.

9. INSPECTION

The Customer and/or the Customer's Successors shall allow Premier Tech or its duly authorized representatives to carry out all necessary monitoring and inspections, as required, for implementation of this Warranty.

If the Customer and/or the Customer's Successors notify Premier Tech of an alleged defect or malfunction of the Ecoflo® Biofilter and that, after inspection, it is found that no such defect or malfunction exists or that such defect or malfunction is excluded from or does not apply to the Warranty, a minimum charge of \$150.00 plus direct expenses shall be paid by the Customer and/or the Customer's Successors for the cost of the inspection.

10. INTERPRETATION

The terms and conditions of this Warranty shall be interpreted according to and governed by the provisions of this Warranty and the legislation in effect in the Province of Quebec.

11. PRIORITY OF THE CERTIFICATE OF WARRANTY

This Warranty supersedes any contract or understanding, written or verbal, entered into between the Customer and Premier Tech. In the event of contradiction between this Warranty and any other documents and/or contracts entered into between the Customer and Premier Tech, this Warranty shall prevail.

12. PURCHASERS AND SUCCESSORS

Subject to the provisions of this Warranty and especially those of section 8, this Warranty shall continue to be valid for Subsequent Purchasers and Successors and shall continue to have full effect until the end of the agreed Warranty period provided for in section 2 of this Certificate.

Notice of New Property Owner

Send a copy to Premier Tech Aqua.

Name of previous the owner: _____

I, the undersigned, _____ hereby declare that I have acquired the property located at

_____	_____	_____	_____
Civic Number	Street	City	Province or State
_____	() _____	_____	
ZIP or Postal Code	Phone number		

I have read and I understand the Warranty provided by Premier Tech Technologies Ltd for the Ecoflo® Biofilter. I wish to benefit from this Warranty for the remaining period, if any, and from the date of the transfer of ownership, that is, _____. I accept to be bound by this Warranty and by any and all of the sections, undertakings and conditions set forth therein. I have had the opportunity to examine the Ecoflo® Biofilter and declare myself satisfied with it at the time of this transfer. I ask Premier Tech Technologies Ltd. to take note of this transfer of ownership.

Signature: _____ Date: _____

Name of new owner: _____
(block letters)

Language preference: English French New owner's e-mail address: _____