

Installation guide

ECOFLO[®]

Ecoflo compact biofilter | Fiberglass
EC5, EC7, and ST/STB model series

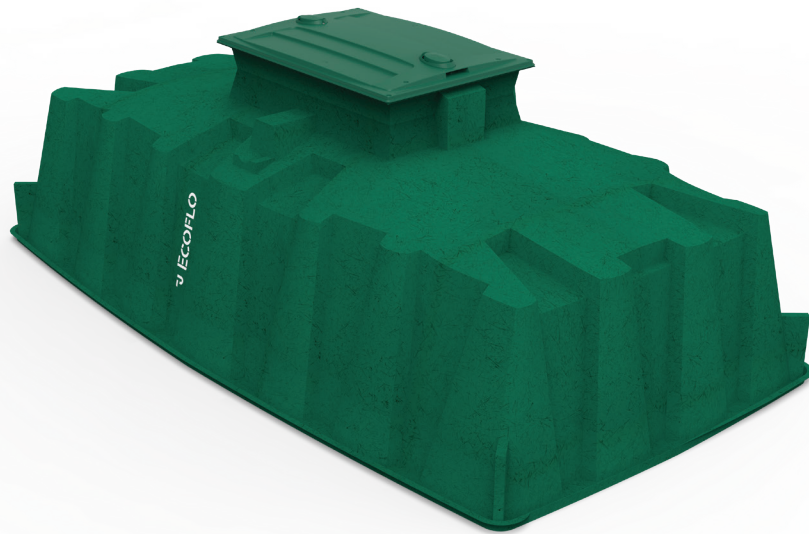

This guide contains the information required to install the fiberglass Ecoflo compact biofilter EC5, EC7, and ST/STB model series. The installation must be performed by a duly trained installer. A list of installers can be provided by contacting Premier Tech at 1 800 632-6356.

TABLE OF CONTENTS

<i>Technical data sheets</i>	2
1 - Description of system components	3
2 - Location of the components and specific instructions	4
3 - Shipping and handling	9

Ecoflo® compact biofilter – Fiberglass EC5, EC7, and ST/STB model series

Material used

- **shell:** fiberglass and polyester resin composite
- **lid, central support, tipping bucket, distribution plates and sampling device:** plastic
- **filtering media:** organic natural fibers

If you have any questions or comments please contact the customer service at 1 800 632-6356.

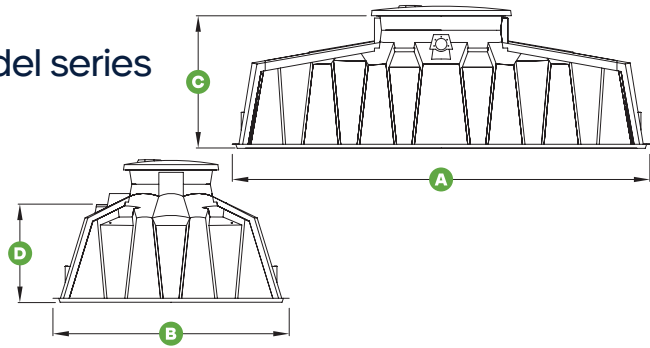

Unit size	5.0			6.5			7.5		
Model series	EC5	EC7	ST/STB	EC5	EC7	ST/STB	EC5	EC7	ST/STB
Models	ECF-650-O	EC7-925-F	ST-500	ECF-860-O	EC7-1200-F	ST-650	ECF-1000-O	EC7-1400-F	ST-750
Type of bottom	Open bottom								
Treatment capacity	650 gal/day (2,450 L/day)	925 gal/day (3,500 L/day)	420 gal/day (1,590 L/day)	860 gal/day (3,250 L/day)	1,200 gal/day (4,500 L/day)	600 gal/day (2,270 L/day)	1,000 gal/day (3,750 L/day)	1,400 gal/day (5,250 L/day)	695 gal/day (2,630 L/day)
Discharge	gravity								
Length A	11' (3,345 mm)			13' 8-1/2" (4,175 mm)			15' 5-1/2" (4,708 mm)		
Width B	7' 9" (2,361 mm)			7' 9" (2,361 mm)			8' 1-1/4" (2,467 mm)		
Height C	4' 4" (1,320 mm)			4' 4" (1,320 mm)			4' 4-1/2" (1,130 mm)		
Inlet height D	3' 2" (970 mm)			3' 2" (970 mm)			3' 2" (970 mm)		
Outlet height Fg									
Outlet height Fp									
Water inlet diameter (nominal)	4" (100 mm)								
Water outlet diameter (nominal)									
Height of filtering media	2' 8" (800 mm)								
Treatment surface area	54 ft ² (5 m ²)			70 ft ² (6.5 m ²)			75 ft ² (7.5 m ²)		
Maximum dosing volume									
Total storage volume above alarm float									
Weight* (shell only)	250 lb (115 kg)			300 lb (135 kg)			320 lb (145 kg)		

* Weights indicated are approximate and not binding (for handling and lifting purposes only).

Not applicable

1 DESCRIPTION OF SYSTEM COMPONENTS

Lid

- protects inner components and provides access into the system

Insulating board

- directs airflow towards the far ends of the unit
- seals the interior of the system (using cable ties)

Shell

- houses the system's components
- allows for the connection of the water and air supply lines
- collects the treated effluent

Central support

- supports the tipping bucket and one end of the distribution plates
- allows air exchange between the surface and base of the filtering medium

Tipping bucket and distribution plates

- uniformly distributes wastewater on both sides of the filtering medium
- uses hydraulic events to ensure self-cleaning of the distribution plates

Filtering medium

- supports the microbial flora that digests the matter in percolating wastewater
- filters the solid wastes contained in effluent
- maintains humidity levels to maintain biomass in absence of hydraulic events

Sampling device

- Allows for the collection of treated effluent samples.

One bag containing the owner's manual (not pictured)

Six plastic cable ties (not pictured)

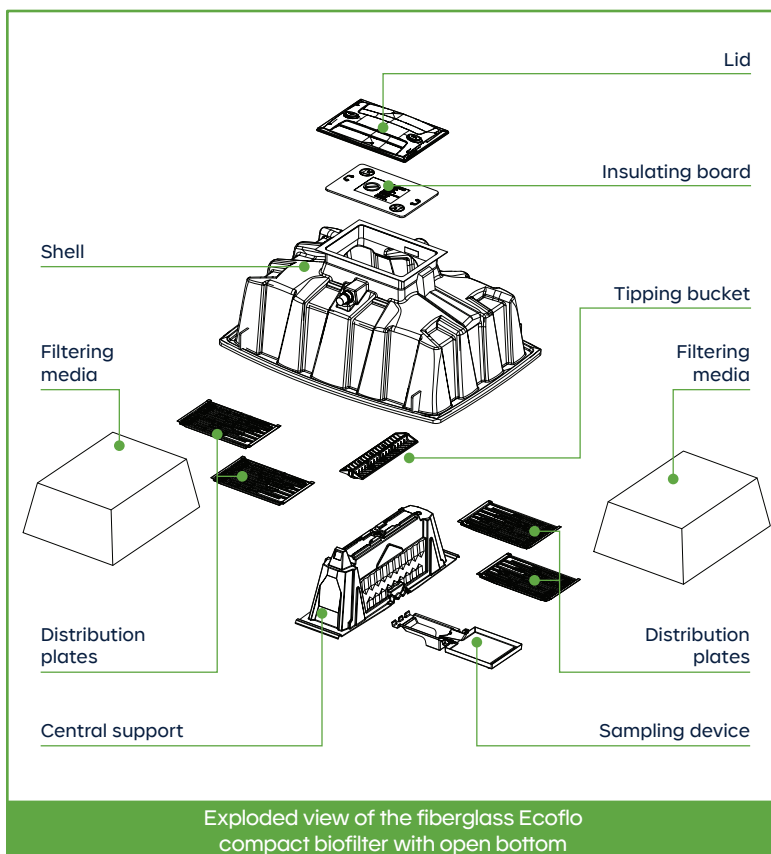

2 INSTALLATION SEQUENCE

IMPORTANT: THE INSTALLER IS RESPONSIBLE FOR TAKING THE NECESSARY SAFETY MEASURES AT ALL STEPS OF THE INSTALLATION. THIS INCLUDES THE USE OF HARDHATS, GLOVES, BOOTS, SAFETY GLASSES, MASKS, ETC.

2.1 ABSORPTION BED, SAMPLING DEVICE, AND CENTRAL SUPPORT



Excavate and prepare the absorption bed according to the standards specified in the fiberglass Ecoflo compact biofilter design guide.

Place a minimum 8" (200 mm) layer of clean crushed stone $\varnothing \frac{3}{4}$ " (20 mm).

Place **the sampling device on the layer of crushed stone. Ensure the flat part of the sampling device is installed on the left side of the inlet pipe** (when facing towards the absorption bed from the primary/septic tank). The sampling device must be centered beneath the central support.

IMPORTANT:

- Never install the absorption bed within 6' 6" (2 m) of a tree.
- The fiberglass model of the Ecoflo compact biofilter **does not** support any risers. The depth of the absorption bed is therefore very important.

INSTALLATION ON A SLOPED SITE

- The fiberglass Ecoflo compact biofilter must be installed perpendicular to the slope on sloped sites.
- Ensure the profile of the final grade around the Ecoflo compact biofilter is such that surface water flows away from the septic system and all of its components.
- The base of the retaining wall, if present or installed, must have adequate draining to ensure that the soil and septic system remain stable while water drains through the bottom of the fiberglass Ecoflo compact biofilter.
- Ensure there is a minimum distance of 20' (6 m) between the fiberglass Ecoflo compact biofilter and the retaining wall.
- Ensure there is a minimum distance of 10' (3 m) between the absorption bed and the retaining wall.
- If there is no retaining wall, the backfill material must be selected and placed to ensure the fiberglass Ecoflo compact biofilter's stability and avoid any movement.

2.2 SHELL INSTALLATION AND LEVELING

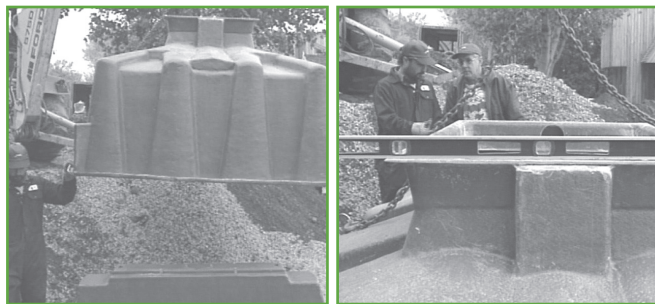

Install the shell onto the central support. Ensure the central support is properly embedded into the shell. The central support's pipe must be opposite the water inlet.

Ensure the shell and central support are both fully level and firmly in contact with the surface of the clean crushed stone.

NOTE: Never install a riser on the fiberglass Ecoflo compact biofilter.

2.3 GEOTEXTILE INSTALLATION AND INITIAL BACKFILL



Place a geotextile over the crushed stone layer to protect it against contamination or obstruction from objects or particles. The geotextile must only be placed on the crushed stone surrounding the Ecoflo compact biofilter—do not place any geotextile directly beneath the fiberglass shell.

Start the initial backfill by carefully placing backfill material over each of the shell's four corners to stabilize the unit. Then, backfill the two long sides followed by the two short sides in successive 12" (30 cm) layers. Note that the backfill material must be laid down rather than pushed. Premier Tech recommends **not** using a bulldozer for this step.



Backfill the fiberglass unit with sandy material up to 2" (50 mm) below the lid. The backfill material should not contain any organic matter, impervious soil, stones, rocks, debris or other object that might damage the shell. Do not overload the shell with backfill material or heavy equipment. A perimeter should be set around the installation during landscaping to prevent vehicles from driving over the Ecoflo compact biofilter.

2.4 INLET CONNECTION

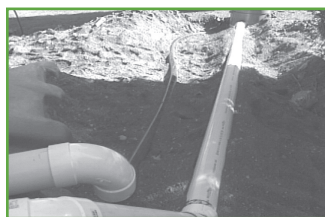

Connect the pipe arriving from the primary/septic tank to the water inlet of the Ecoflo compact biofilter while making sure to maintain a constant downslope along the entire length of the pipe to the inlet of the Ecoflo compact biofilter. The soil under the pipe must be adequately backfilled with proper material to prevent any settling under this connection.

An installation with two Ecoflo compact biofilter units using gravity distribution must consider using a flow divider to create even distribution between the biofilter units. Premier Tech Water and Environment offers several pressurized flow dividers. Learn more at PT-WaterEnvironment.com/ProSpace.

CONNECTING THE WATER INLET PIPE TO THE FLEXIBLE ADAPTER

1. Loosen the pipe clamp without removing it from the adapter. Push the clamp to the end of the adapter.
2. Clean the Ø 4" (100 mm) pipe. Apply a coat of PVC primer inside the fitting connections and around the pipes before gluing.
3. Take the end of the pipe that will be inserted into the adapter. Apply PVC cement on the outside of it and on the inside of the adapter.
4. Insert the pipe into the adapter until it touches the end of the adapter.
5. Bring the clamp back to its original position and tighten it around the adapter and the Ø 4" (100 mm) pipe.



CONNECTING THE WATER INLET PIPE WHEN USING A PUMPING STATION WITH THE ECOFLO COMPACT BIOFILTER

The following instructions must be taken into account if the installation includes a pumping station between the primary/septic tank and the Ecoflo compact biofilter:

- Premier Tech Water and Environment recommends a dose of 8-10 gal (30-40 L) per hydraulic event (approximately 10 tipping bucket cycles).
- The pumping station must be watertight from the outside (infiltration) and the inside (exfiltration).
- The water inlet pipe (Ø 1-½" [38 mm] flexible pipe) is connected to an inlet adapter (provided with Premier Tech Water and Environment's PSA-240 pumping station). This pipe shall also be connected to the inlet of the Ecoflo compact biofilter (nominal diameter of 4" [100 mm]). Note that the connection adapter must be installed to break up the jet of water coming from the pumping station.
- A ventilation pipe must be installed between the pumping station and the Ecoflo compact biofilter to ensure adequate ventilation. This ventilation pipe is connected to the adapter and equipped with a Y-tee.
- The residence must be equipped with a functional air vent that meets the applicable standards.
- The pumping station must be accessible at all times.

For further clarity regarding these instructions, please refer to the diagram below and to Premier Tech Water and Environment's pumping station installation guide on [PT-WaterEnvironment.com/ProSpace](https://www.pt-waterenvironment.com/prospace).

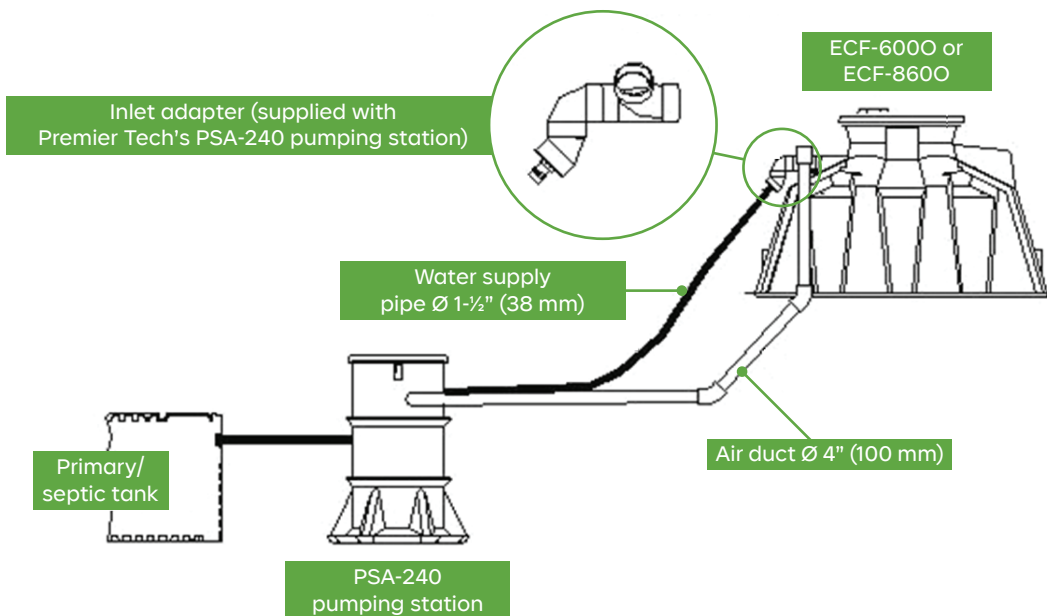

An installation with two Ecoflo compact biofilter units that cannot use gravity distribution or with three or more Ecoflo compact biofilter units must consider using a flow divider to create even distribution between the biofilter units. Premier Tech Water and Environment offers several pressurized flow dividers. Learn more at [PT-WaterEnvironment.com/ProSpace](https://www.pt-waterenvironment.com/prospace).

2.5 FINAL BACKFILL AND FILTERING MEDIUM INSTALLATION



Complete the backfill. Note that the backfill material must be laid down rather than pushed onto the unit. Premier Tech recommends **not** using a bulldozer for this step. The backfill material must be sandy and free of rocks or stones. Plan for the layer of vegetation and make sure that the system's lids are 2" (50 mm) above the surface once the landscaping has been completed. Never install a riser on the fiberglass Ecoflo compact biofilter.

Fill the tank with filtering medium according to your model series.

Model series EC5 and EC7: Create a single layer of filtering medium using each bag of coconut husk fragments.

Model series ST/STB: Create two layers of filtering medium. Use each bag of coconut husk fragments for the bottom layer, then use each bag of peat for the top layer.

Fill the Ecoflo biofilter with the filtering media. Pour the filtering media bags with equal amounts on each side of the central until the filtering medium's surface reaches the base of the distribution plates. Use a rake to level the surface of the filtering medium. The final surface of the filtering medium should be right beneath the distribution plates.

WARNING!

- Do not allow backfill material to enter the tank while working inside.
- Do not compact or walk on the filtering medium.
- Carefully level the surface of the filter medium.
- Prevent any pieces of filtering medium from falling into the access well during filling.

2.6 INSTALLING THE DISTRIBUTION PLATES



- Install the distribution plates by placing them on their support rails at both ends of the shell.
- Ensure that the arrow on each distribution plate is oriented toward the end of the shell.
- Place the first plate on the left side of the shell, then place the second plate directly against it.
- Repeat the same installation on the right side of the shell (two plates on each side).
- The distribution plates should rest on the central support and must be secured to it with four plastic cable ties.

The distribution plates should rest on top of the central support and must be attached to it with four black plastic tie-wraps provided for this purpose.

2.7 INSTALLING THE TIPPING BUCKET

Once the distribution plates are in place, install the tipping bucket by inserting its locking catches into the anchor slots of the central support, then press down on the opposite end to secure it. Ensure the end of the inlet pipe is positioned lower than the water inlet to allow proper water flow into the system. Test the tipping bucket by tipping it from left to right to confirm that nothing is obstructing its movement. Adjust the level of the tipping bucket if necessary.



2.8 IDENTIFICATION AND WARRANTY SEALS

Check the Ecoflo compact biofilter model installed and the type of discharge on the provided sticker. Install the insulation board and seal it in place using the two Premier Tech fasteners. Once in place, these fasteners secure the Ecoflo compact biofilter's collar to the handle of the insulation board. Finally, use the lag screws to close the main access lid. Note that no specific actions are needed from the owner to begin using the system.



DON'T FORGET THE INSPECTION PERMIT, WHERE APPLICABLE.

IMPORTANT REMARKS

- ❑ Always keep your septic system lids accessible. NEVER cover them with mulch, dirt, or any permanent structure.
- ❑ Once the landscaping work has been completed, the lids of your septic system must be 2" (50 mm) higher than the surface of the landscaped terrain.
- ❑ Never install a riser on the access of the fiberglass Ecoflo compact biofilter.
- ❑ Never plant a tree within 20' (6 m) of the fiberglass Ecoflo compact biofilter's lid or within 6' 6" (2 m) of the absorption bed.
- ❑ NEVER open the lids or enter the primary/septic tank or Ecoflo compact biofilter.
- ❑ NEVER connect a drainpipe, roof gutter, sump pump, or air conditioner drain to the septic system.
- ❑ Never drive a vehicle or place objects weighing more than 500 lb (225 kg) within a radius of 16' 5" (4 m) from the septic system's lids (remember to notify any landscaper of this instruction).
- ❑ ALWAYS keep the top of the septic system clear of any material that might create an excessive load (for instance, compacted snow).
- ❑ NEVER discharge content or water from a water softener, spa, or pool backwash into your septic system.
- ❑ NEVER discharge wastewater from a recreational vehicle into your septic system.
- ❑ NEVER use automatic toilet bowl cleaners.
- ❑ If there is a delay between the initial installation and the final landscaping work, install reference marks and protective barriers that identify the Ecoflo compact biofilter's location. This will prevent any motor vehicle traffic on the unit and will take note of the system's final grade.

- If a pumping station is installed between the primary/septic tank and the Ecoflo compact biofilter, the pumping station must be connected to the Ecoflo compact biofilter by an airflow duct.
- The residence must be equipped with a functional air vent that meets the applicable standards. Premier Tech Water and Environment strongly recommends using a pipe measuring 4" (100 mm) in diameter.
- Hand the plastic bag containing the owner's manual and maintenance contract to the owner. The pouch is located under the water inlet cap.
- The homeowner must complete and sign Premier Tech's maintenance agreement. The homeowner must keep the white copy, give the yellow copy to their municipality, and send the pink copy to Premier Tech Water and Environment.

Respecting these guidelines contributes to the wastewater treatment system's proper operation. Failure to abide by these guidelines may, at Premier Tech Water and Environment's discretion, render the system's warranty invalid.

3 SHIPPING AND HANDLING

3.1 SHIPPING FROM THE DISTRIBUTOR TO THE INSTALLATION SITE

- Use a vehicle with enough space to load and ship the Ecoflo compact biofilter.
- Use appropriate straps to adequately fasten the Ecoflo compact biofilter.
- Use the fiberglass shell's loading rings to load it onto the trailer or vehicle whenever possible.
- The carrier is responsible for complying with traffic regulations and for any damage occurring during shipping and handling.

3.2 HANDLING

- Avoid any handling methods that might damage the Ecoflo compact biofilter.
- Use the four (4) lift rings on the shell to unload the Ecoflo compact biofilter. If using a forklift, ensure the forks are long enough to ensure even and stable load distribution.
- The handler is responsible for any damage that occurs during handling operations.

3.3 LOAD CONFIGURATION

- The configuration depends on the type of vehicle used to bring the Ecoflo compact biofilter to the site.
- The vehicle must have a minimum surface area of 14' x 8' (4.2 m x 2.4 m) to accommodate the Ecoflo compact biofilter.
- The carrier must have enough space to transport the filtering medium bags (the bags can be taken off the pallet). A pallet of filtering medium bags has a surface area of approximately 5' x 4' (1.5 m x 1.2 m).

Problems, questions, or comments?

Please contact **Premier Tech Water and Environment** by calling **1-800-632-6356**.

