



Protect our properties
and our environment

REWATEC[®]

Activated Sludge Process (ASP)



Proven and reliable wastewater treatment

The Rewatec Activated Sludge Process (ASP) is an innovative sewage treatment plant that is engineered to treat wastewater for a wide range of residential and commercial projects.

Proven in the industry for over 15 years, the Rewatec ASP combines high reliability with a robust and durable design, providing an efficient and long-lasting solution for complete peace of mind.

Designed, manufactured and tested in accordance with EN12566-3 and in compliance with S.R. 66:2015, our standardised range of Rewatec ASP sewage treatment plants provide an effluent quality better than 20mg/L biological oxygen demand (BOD), 30mg/L total suspended solids (TSS), 20mg/L ammonia (NH₃-N).

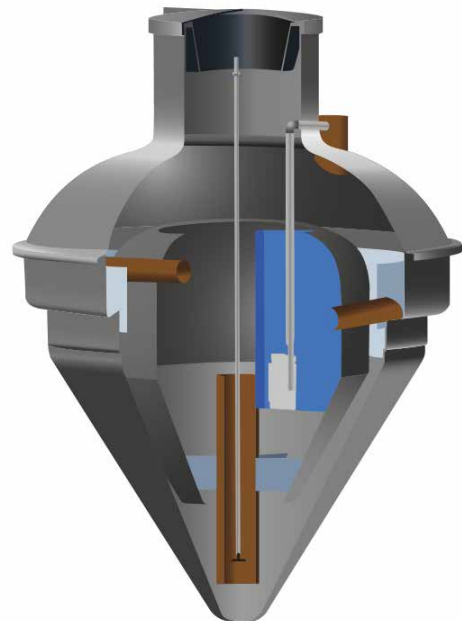

How does the Rewatec ASP work?

The Rewatec ASP comprises of a single tank. Within this tank there is an inner central biozone chamber and an outer settlement zone.

Wastewater flows into the tank and settles in the central biozone chamber where it is aerated through the central diffuser. A coarse bubble diffuser, housed in a draft tube, introduces the air that provides oxygen to the bacteria which then treats the wastewater.

The treated water then enters the outer settlement zone. Here, settled solids are drawn back to the draft tube and returned to the biozone chamber for further treatment.

The final treated effluent leaves the Rewatec ASP via a weir at the outlet level that extends around the circumference of the tank. The movement and exit of water throughout the ASP is by gravity displacement. For situations where it isn't possible for the final effluent to gravitate to the final discharge location, a Rewatec ASP with an integral pump is available.

OPERATION

Inlet for incoming wastewater

Biozone and aeration chamber to promote treatment

Draft tube to house the bubble diffuser

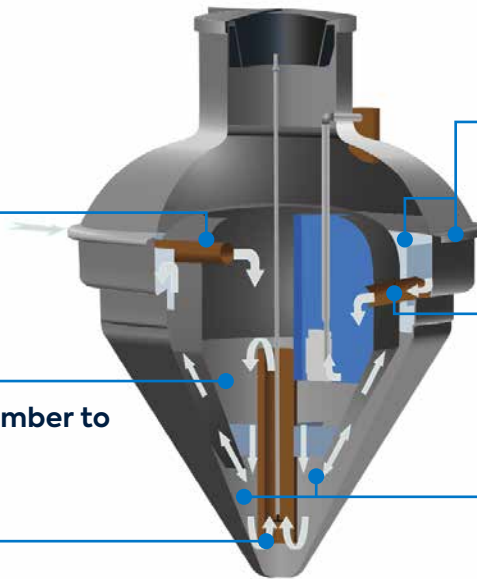

Discharge via gravity or via an integral pump

Final effluent leaves the ASP via a weir

Treated effluent - settlement zone

APPLICATIONS

The Rewatec ASP has been installed in a variety of applications across Ireland. This includes:

- Single houses
- Small communities or developments
- Smaller commercial applications



Advantages for you

EASY INSTALLATION

- Typically only uses a 200mm deep concrete base followed by a self-compacting backfill
- Deeper inverts can be easily accommodated
- Easy to follow installation guidelines

HIGHLY RELIABLE

- CE marked
- Complies with the EPA code of practice
- Thousands of installations across Ireland

QUICK AVAILABILITY

- Reliable order tracking
- Manufactured in Ireland for rapid dispatch
- Ready to install solution

Advantages for your customers

ECONOMICAL OPTION

- Low running costs
- Competitively priced
- Low emptying frequency

BUILT TO LAST

- Leak-proof
- Robust and durable GRP shells
- Peace of mind performance with no moving parts

COMPACT AND DISCREET

- Quiet and odourless operation
- Complete below ground installation
- Minimal impact on gardens and landscapes

RANGE AND OPTIONS

With a range of innovative options available, the Rewatec ASP can serve a population range from 1 to 8 people (PE). All Rewatec ASP sewage treatment plants can cope with lower than the nominal population (PE) loading.

SERVICES

Premier Tech provide a range of cost effective services to help preserve the lifespan of every Rewatec ASP.

From routine servicing and maintenance, to emergency call outs and repairs, our experienced service engineers will guarantee peace of mind.

WARRANTY

For over 50 years, we have proudly developed sustainable and long-lasting products that make a real difference for our customers, our professional partners, and, above all, our planet.

Our experience in the industry allows us to give you a 25 year warranty for our Rewatec ASP sewage treatment plants and a 12 month internal parts warranty.

Rewatec ASP specifications

Rewatec ASP	6 PE	8 PE
Hydraulic (L/d)	900	1,200
Organic load (g BOD5/day)	360	480
Ammonia (g NH ₃ /day)	48	64
O/A diameter	2,080	2,080
From standard outlet invert (mm)	1,390	1,390
Standard outlet invert (mm)	800	800
Outlet invert to base - gravity (mm)	1,450	1,450
Pipework fitting (mm)	110	110
Cover size (mm)	800	800



PT Water and Environment

Quartermown Industrial Estate
Mallow, Co Cork
IRELAND P51 PY20

+353 (0) 22 51411
sales.ptwe.ie@premiertech.com
PT-WaterEnvironment.ie



The information contained in this document was current and consistent with the information available at the time of publication. Premier Tech Ltd. makes no warranties or representations as to its accuracy. Because of its continuous improvement policy, Premier Tech Ltd. and its affiliated companies reserve the right to change and/or discontinue the manufacture of any product and/or modify technical data and prices, for any reason whatsoever and at its sole discretion, without further notice and without liability to anyone in this regard.

© 2022 Premier Tech Ltd. All rights reserved.
Printed in Ireland

Ireland
20220404