



INTEGRATED UV DISINFECTION (DIUV)

ECOFLO[®] | REWATEC[™]

DISCOVER THE ADVANTAGES OF OUR NEW UV OFFER



NEW PRICE

Our more aggressive price point is now lower than ever.

IMPROVED DESIGN

Our new, more robust design comes pre-assembled in Ecoflo and includes 100' (30 m) of electrical cables.

WI-FI ALERTS FOR PEACE OF MIND

Our UV disinfection unit now sends email alerts to customers and our team.

GUARANTEED 24-HOUR SERVICE

When we receive email alerts, we notify customers right away and a service team tackles the problem in less than 24 hours.

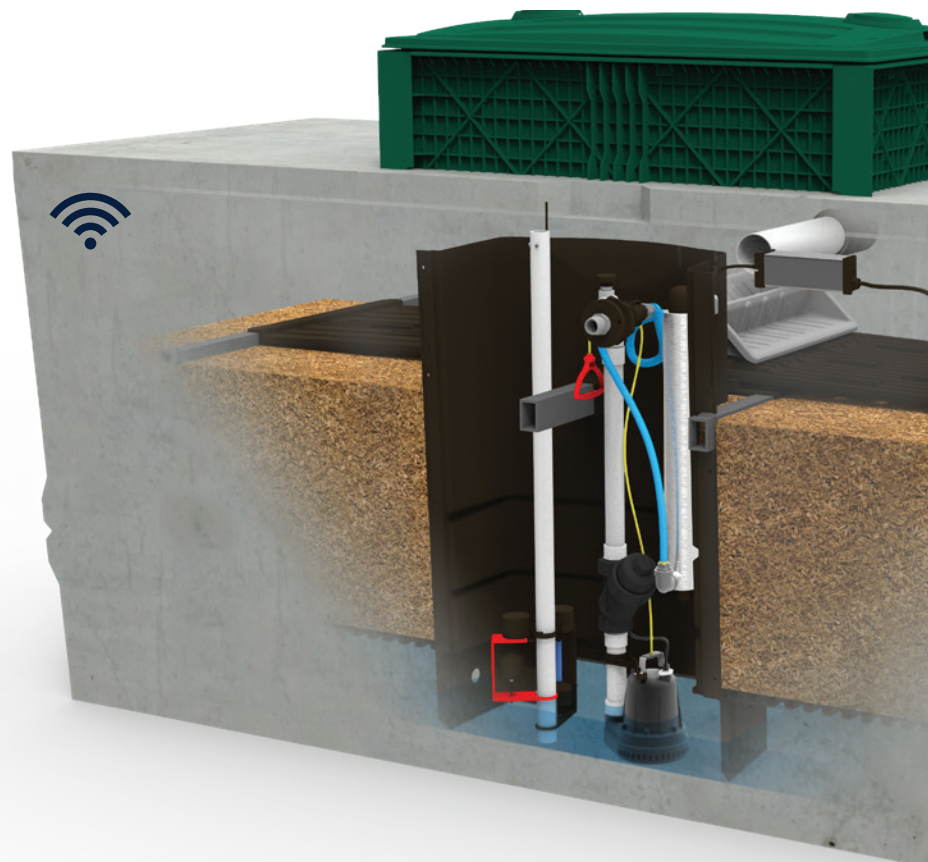

OUR TOTAL-PROTECTION COMMITMENT



Original parts, replacement parts, and labour.

Preserve the environment for future generations and protect public health by adding our reliable UV disinfection unit to Ecoflo.

ENVIRONMENTAL PROTECTION

Our UV disinfection unit kills wastewater pathogens, so you can safely discharge effluent into a watercourse or ditch. The unit never releases untreated wastewater, even if there is a failure.

CUSTOMER PROTECTION

Ecoflo is designed with a 72-hour buffer capacity. If there is an issue with our UV disinfection unit, a service team responds in less than 24 hours – guaranteed.

PARTNER PROTECTION

Our partners can rest easy after installing our UV disinfection unit. Thanks to built-in Wi-Fi alerts, any issues will be found and fixed in a flash.

Isolated ballast

Easy maintenance

70 W UV lamp

Integrated pump

Wi-Fi alarm

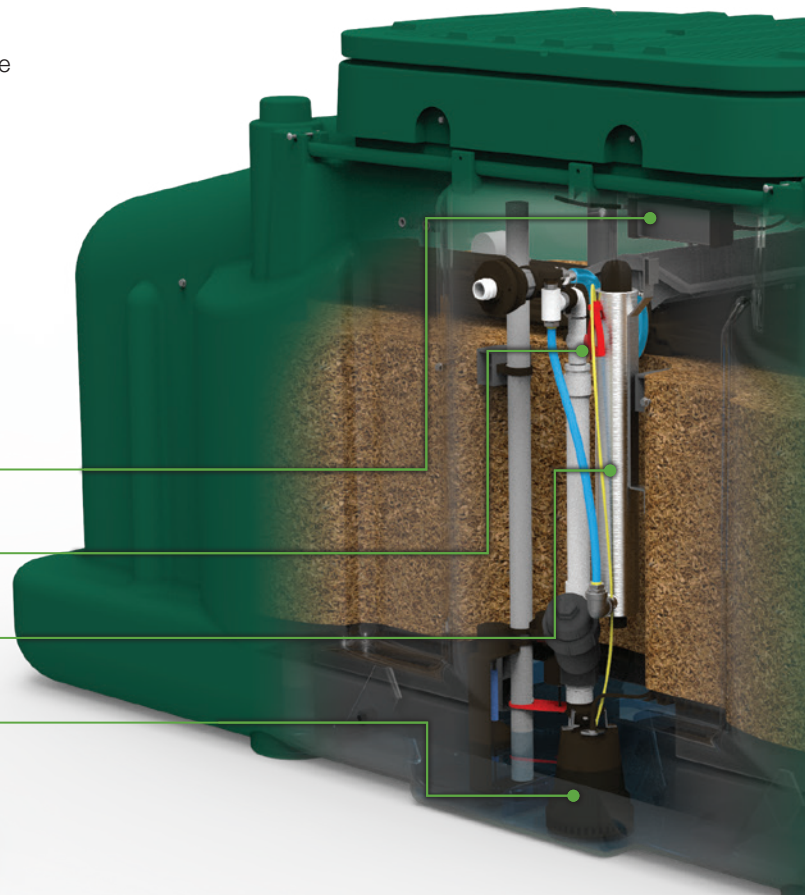

PT Water and Environment

+1 800 632-6356

info.ptwe.na@premiertech.com

PT-WaterEnvironment.com



The information contained in this document was up-to-date and consistent with the information available at the time of publication. Premier Tech Ltd. makes no warranties or representations as to its accuracy. Because of its continuous improvement policy, Premier Tech Ltd. and its affiliated companies reserve the right to change and/or discontinue the manufacture of any product and/or modify technical data and prices, for any reason whatsoever and at its sole discretion, without further notice and without liability to anyone in this regard. ECOFLO®, REWATEC™, PREMIER TECH®, and PREMIER TECH & DESIGN™ are trademarks of Premier Tech Ltd. or its affiliates. Ecoflo® is protected under patents: CA2499637; US7097768; ES2285173; EP1539325 (BE, FR). Notice issued on 2019-01-11. For current data regarding all patent application(s) and patent(s) for this product or any part thereof, consult the website patentmarking.premiertech.com (reference: 3685).

© 2020 Premier Tech Ltd. All rights reserved.
Printed in Canada

CAN/USA
20200813