

PTE

FILTER CONTAINER, SEPTIC TANK RISER, ADAPTER AND LID



Premier Tech Environment (PTE) has developed a complete line of decentralized wastewater treatment products and systems. PTE Filter Container, Septic Tank Adapter, Access Risers and Lid are all compatible, lightweight and easy to handle.

ADVANTAGES

TLF-240 PTE Filter Container
TLF-240F PTE Filter Container
(with EFT-080 Effluent Filter)
TLF-240P PTE Filter Container
(with PL-122 Polylok Effluent Filter)

- Can be used to hold an effluent filter, sampling tank or access port
- Suitable for all types of installation
- Flat surfaces for easy pipe connection on every face
- Easy installation and access
- Watertight

PSR-060 and PSR-140
PTE Risers

- Easy to install
- Corrosion-resistant
- Robust

TAD-240 PTE Adapter
for concrete tanks

- Compatible with all septic tanks
- Allows access to septic tanks
- Robust

LID-240 PTE Access Lid

- Easy to install
- Blends nicely with the landscape
- Lightweight
- Secure



**Premier Tech
Environment**

TLF-240

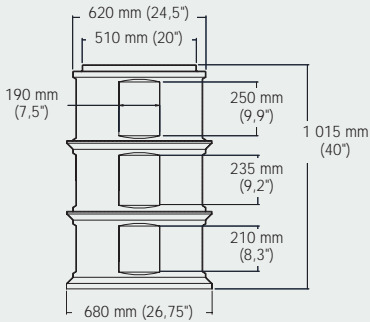

PSR-060

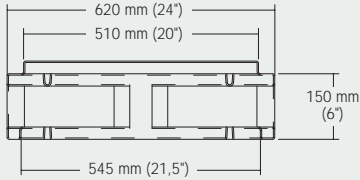

PSR-140

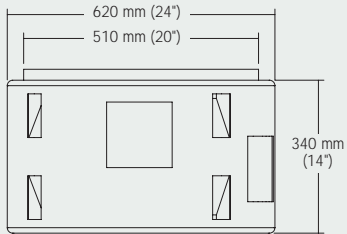

TAD-240

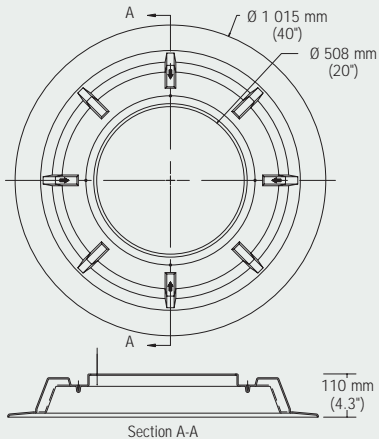

DESCRIPTION

The TLF-240 PTE Filter Container with a PTE Effluent Filter integrated is especially designed for cases where it's not possible to install it directly in the septic tank and to allow safe, easy access for filter inspection and maintenance. It is also designed to serve as a sampling tank or an access port.

The PSR-060 and PSR-140 PTE Risers are designed for the PTE Filter Container but are also compatible with the PSA-240 PTE Pumping Station, the PTE Adapter and the PTE Septic Tanks and can be extended from 150 mm to 700 mm (6" to 28"). The PSR-060 PTE Riser can also be used as an access opening for septic tanks, in which case it is cast in concrete tanks during manufacturing.

The TAD-240 PTE Septic Tank Adapter allows access to existing septic tanks. Its unique design retrofits all residential septic tanks currently on the market.

The LID-240 PTE Access Lid fits all the above components (PTE Filter Container, Risers, Adapter, Pumping Station and Septic Tanks). It is lightweight, secure and easy to handle.

FEATURES

TLF-240 PTE Filter Container

- Polyethylene construction
- Standard height of 1015 mm (40") and diameter of 680 mm (26.75")
- Capacity of 200 l (53 US gal, 44 Imp. gal/d)
- One-piece design
- Height of 150 mm (6")

TAD-240 PTE Adapter

- Polyethylene construction
- 508 mm (20") opening

PSR-060 6" PTE Riser

- Height of 150 mm (6")

PSR-140 14" PTE Riser

- Height of 355 mm (14")

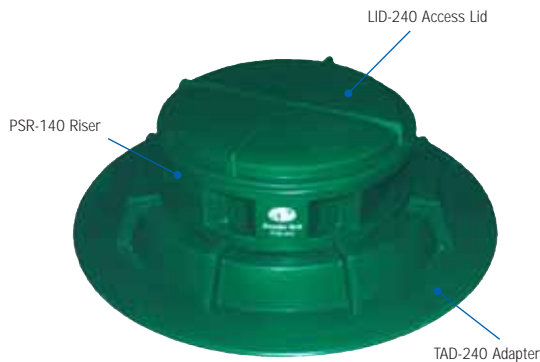

EFT-080 Effluent Filter in a Filter Container



**Premier Tech
Environment**

☎ 1 800 632-6356
☎ 418 862-6642
✉ pte@premiertech.com
🌐 www.ptenv.com

Premier Tech Environment (PTE) is a business unit of Premier Tech, a company with over 80 years of experience and more than 1,600 team members, of which 175 work for PTE.

Internationally renowned in America, Europe and Asia, PTE operates in the field of decentralized wastewater treatment for the residential, commercial, community, municipal and industrial sectors. With more than 30,000 systems installed and maintained, PTE is considered a reference in its field through its innovative approach and its superior technologies commercialized for the last 30 years.

The information contained in this document is based upon the latest information available at the time of publication and is designed to provide you with a general introduction to our products. We make no warranties or representations as to its accuracy. We are continually updating and improving our products and reserve the right to amend, discontinue or alter or change specifications and prices without prior notice.

© Premier Tech Ltd., 2007

🇨🇦 Printed in Canada